

reasoning summarized in the capital–coercion diagram invites us to rethink European state formation in terms of the interplay of cities and states, and thereby captures some broad regularities in state formation. It clearly improves on the portrayal of English, French, or Prussian state formation (or some generalization of the three) as the core process, and all others as attenuated or failed attempts to follow the same path.

Over the centuries before the nineteenth, however, states had long diverged as they fashioned military forces in situations of very different relations between capital and coercion. Alternative paths of state formation, in their turn, led to different forms of resistance and rebellion, different state structures, and different fiscal systems. If so, standard debates about the transition from feudalism to capitalism and the rise of national states have concentrated too heavily on the experiences of France, England, and a few other massive states, while neglecting a major determinant of the actual character of states. Great landlords overwhelmed both capitalists and kings in Poland, but were practically nonexistent in Holland. The “feudalism” of Florence and its *contado* differed so greatly from the “feudalism” of Hungary that it hardly seems worthwhile to cover them both by the same term.

More than anything else, the relative importance of cities, financiers, and capital in a zone of state formation significantly affected the kinds of states that took shape there. Mobilizing for war had significantly different effects depending on the presence or absence of substantial capital and capitalists. A closer look at the actual operation of European states – the business of the next chapter – will clarify how the availability and form of capital made such a difference to preparation for war, and how war, in its turn, shaped the durable organizational structure of states.

Chapters 3 and 4 will neglect geographic variation within Europe in favor of placing major changes in war, political structure, and domestic struggle firmly in time. Chapters 5 and 6 (on alternative paths of state formation and the evolution of the international state system) will, in contrast, pay great attention to variation among different kinds of states, before chapter 7 confronts European historical experience with the character of state formation in the contemporary world.

3

How War Made States, and Vice Versa

A BIFURCATION OF VIOLENCE

Despite the current forty-year lull in open war among the world’s great powers, the twentieth century has already established itself as the most bellicose in human history. Since 1900, by one careful count, the world has seen 237 new wars – civil and international – whose battles have killed at least 1,000 persons per year; through the year 2000, the grim numbers extrapolate to about 275 wars and 115 million deaths in battle. Civilian deaths could easily equal that total. The bloody nineteenth century brought only 205 such wars and 8 million dead, the warlike eighteenth century a mere 68 wars with 4 million killed (Sivard 1986: 26; see also Uralis 1960). Those numbers translate into death rates per thousand population of about 5 for the eighteenth century, 6 for the nineteenth century, and 46 – eight or nine times as high – for the twentieth. From 1480 to 1800, a significant new international conflict started somewhere every two or three years, from 1800 to 1944 every one or two years, since World War II every fourteen months or so (Beer 1974: 12–15; Small and Singer 1982: 59–60; Cusack and Eberwein 1982). The nuclear age has not slowed the centuries-old trend toward more frequent, deadlier wars.

That Westerners commonly think otherwise probably results from the fact that war has become rarer among the great powers: France, England, Austria, Spain, and the Ottoman Empire in 1500; France, the United Kingdom, the Soviet Union, West Germany, the United States, and China today; other sets in between. Wars directly involving great powers have, on the average, declined in frequency, duration, and number of participating states since the sixteenth century. They have also, in bitter compensation, become much more severe – especially if we count the number of deaths per month or per year (Levy

1983: 116–49). Among lesser powers, more and more wars, but fairly small ones; among the great powers, fewer and fewer wars, but increasingly deadly ones.

We can read the contrast between great power experience with war and that of other states optimistically or pessimistically. Optimistically, we might suppose that the great powers eventually found less costly ways of settling their differences than incessant wars, and that the same thing will eventually happen to other states. Pessimistically, we might conclude that the great powers have exported war to the rest of the world, and have saved their own energy for destroying each other in concentrated bursts. In either mood, we see an increasingly belligerent world in which the most powerful states enjoy a partial exemption from war on their own terrains and therefore, perhaps, become less sensitive to the horrors of war.

The problem is not, however, that people in general have become more aggressive. As the world has grown more warlike, interpersonal violence outside of the state's sphere has generally declined (Chesnais 1981, Gurr 1981, Hair 1971, Stone 1983). At least that seems to be true of Western countries, the only ones so far for which we have long series of evidence. Although the reports of murders, rapes, and collective violence in our daily newspapers may suggest otherwise, the chances of dying a violent death at some other civilian's hand have diminished enormously.

Homicide rates in thirteenth-century England, for example, were about ten times those of today, and perhaps twice those of the sixteenth and seventeenth centuries. Rates of murder declined with particular rapidity from the seventeenth to the nineteenth centuries. (Because the United States has by far the highest national homicide rate in the Western world, it may be harder for Americans than for others to appreciate how rare interpersonal violence has become elsewhere; in most Western countries suicide is ten or twenty times as common as murder, while the American population's homicide rate approaches its rate of suicide.) If it were not for war, state repression, the automobile, and suicide, the odds of violent death of any kind would be incomparably slimmer in most of the Western world today than they were two or three hundred years ago.

Such thinkers as Michel Foucault and Marvin Becker may be right to attribute part of the change to massive shifts in mentality. But surely a significant contribution came from the increasing tendency of states to monitor, control, and monopolize the effective means of violence. In most of the world, the activity of states has created a startling contrast between the violence of the state's sphere and the relative non-violence of civilian life away from the state.

HOW STATES CONTROLLED COERCION

European states led the construction of that contrast. They did so by building up fearsome coercive means of their own as they deprived civilian populations

of access to those means. For the most part, they relied heavily on capital and capitalists as they reorganized coercion. Yet different states did so in strikingly different ways.

Do not underestimate the difficulty or importance of the change. Over most of European history, ordinary men (again, the masculine form of the word matters) have commonly had lethal weapons at their disposal; within any particular state, furthermore, local and regional powerholders have ordinarily had control of concentrated means of force that could, if combined, match or even overwhelm those of the state. For a long time, nobles in many parts of Europe had a legal right to wage private war; the twelfth-century *Usatges*, or Customs, of Catalonia specifically recorded that right (Torres i Sans 1988: 13). Bandits (who often consisted of disbanded segments of private or public armies) flourished in much of Europe through the seventeenth century. In Sicily, those controlled and protected entrepreneurs of violence called *mafiosi* have terrorized rural populations into our own time (Blok 1974, Romano 1963). People outside the state have often profited handsomely from their private deployment of violent means.

Since the seventeenth century, nevertheless, rulers have managed to shift the balance decisively against both individual citizens and rival powerholders within their own states. They have made it criminal, unpopular, and impractical for most of their citizens to bear arms, have outlawed private armies, and have made it seem normal for armed agents of the state to confront unarmed civilians. By clinging to civilian possession of firearms, the United States now sets itself apart from all other Western countries, and pays the price in rates of death by gunshot hundreds of times higher than its European counterparts; in the proliferation of private weaponry, the United States resembles Lebanon and Afghanistan more than Great Britain or the Netherlands.

Disarmament of the civilian population took place in many small steps: general seizures of weapons at the ends of rebellions, prohibitions of duels, controls over the production of weapons, introduction of licensing for private arms, restrictions on public displays of armed force. In England, the Tudors suppressed private armies, reduced the princely power of great lords along the Scottish border, contained aristocratic violence, and eliminated the fortress-castles that once announced the power and autonomy of the great English magnates (Stone 1965: 199–272). Louis XIII, the seventeenth-century monarch who with the aid of Richelieu and Mazarin rebuilt the armed force of the French state, probably tore down more fortresses than he constructed. But he built at the frontiers, and destroyed in the interior. In subduing magnates and cities that resisted his rule, he commonly demolished their fortifications, reduced their rights to bear arms, and thereby decreased the odds of any serious future rebellion.

At the same time, the state's expansion of its own armed force began to overshadow the weaponry available to any of its domestic rivals. The distinction

between “internal” and “external” politics, once quite unclear, became sharp and fateful. The link between warmaking and state structure strengthened. Max Weber’s historically contestable definition of the state – “a state is a human community that (successfully) claims the *monopoly of the legitimate use of physical force* within a given territory” (Gerth and Mills 1946: 78) – finally began to make sense for European states.

Exactly how civilian disarmament proceeded depended on its social setting: in urban regions, the installation of routine policing and the negotiation of agreements between municipal and national authorities played a major part, while in regions dominated by great landlords the disbanding of private armies, the elimination of walled, moated castles, and the interdiction of vendettas alternated between co-optation and civil war. Coupled with the continued buildup of the state’s armed force, the disarmament of civilians enormously increased the ratio of coercive means in state hands to those at the disposal of domestic rivals or opponents of those currently holding state power. As a result, it has become almost impossible for a dissident faction to seize power over a Western state without the active collaboration of some segments of the state’s own armed forces (Chorley 1943, Russell 1974).

A ruler’s creation of armed force generated durable state structure. It did so both because an army became a significant organization within the state and because its construction and maintenance brought complementary organizations – treasuries, supply services, mechanisms for conscription, tax bureaux, and much more – into life. The Prussian monarchy’s chief tax-collection agency came into being as the General War Commissariat. During the later seventeenth century, England’s successive republican and monarchical governments, intent on countering French and Dutch naval power, built royal shipyards into the country’s largest concentrated industry. Such empire-building organizations as the Dutch East India Company became enormously influential elements of their national governments (Duffy 1980). From AD 990 onward, major mobilizations for war provided the chief occasions on which states expanded, consolidated, and created new forms of political organization.

WARS

Why did wars occur at all? The central, tragic fact is simple: coercion *works*; those who apply substantial force to their fellows get compliance, and from that compliance draw the multiple advantages of money, goods, deference, access to pleasures denied to less powerful people. Europeans followed a standard war-provoking logic: everyone who controlled substantial coercive means tried to maintain a secure area within which he could enjoy the returns from coercion, plus a fortified buffer zone, possibly run at a loss, to protect the secure area. Police or their equivalent deployed force in the secure area, while armies

patrolled the buffer zone and ventured outside it; the most aggressive princes, such as Louis XIV, shrank the buffer zone to a thin but heavily-armed frontier, while their weaker or more pacific neighbors relied on larger buffers and waterways. When that operation succeeded for a while, the buffer zone turned into a secure area, which encouraged the wielder of coercion to acquire a new buffer zone surrounding the old. So long as adjacent powers were pursuing the same logic, war resulted.

Some conditions for war varied, however. Every state’s particular brand of warmaking depended on three closely-related factors: the character of its major rivals, the external interests of its dominant classes, and the logic of the protective activity in which rulers engaged on behalf of their own and dominant classes’ interests. Where rivals were commercial seafarers, piracy and privateering simply continued, regardless of the formal state of war and peace, while where landlord-dominated agrarian powers lived shoulder to shoulder, disputes over control of land and labor – especially at moments of disputed succession – precipitated resort to arms much more frequently. When small maritime powers owned large overseas empires, protection of interests drew them into the patrolling of sea lanes, and therefore into inevitable battles with others who coveted the same trade. Because the constellation of rivalries, the nature of dominant classes, and the demands of protection changed fundamentally over the thousand years we are surveying, the characteristic causes of war changed as well.

Coercion is always relative; anyone who controls concentrated means of coercion runs the risk of losing advantages when a neighbor builds up his means. In Europe before 1400, the control of most states by kin groups compounded the competition. Where rulers formed a kin group, the tendency of prospering kin groups to expand and to seek places for growing numbers of heirs incited conquest, and therefore sharpened rivalries. Inter-marriage among ruling families, furthermore, multiplied the claims of powerful dynasties to vacated thrones. In the fragmented sovereignty of Europe, rivals – whether kinsmen or not – were always close at hand, but so was a coalition nearly always available to keep any particular center from expanding indefinitely.

For a long time, furthermore, larger states such as Burgundy and England always harbored *internal* rivals to the current sovereign, armed groups who had also some claim to rule, and who sometimes served as implicit or explicit allies of external enemies. In China, once the vast imperial apparatus formed, a waxing empire had plenty of enemies, but no real rivals inside or outside its territories. Mongols constantly threatened along China’s northern border, and intermittently staged devastating raids into the empire, but only once actually took it over. In general, the Mongols were better at exacting tribute than they would have been at running the state apparatus themselves. Chinese dynasties collapsed when the empire’s administrative reach exceeded its grasp, when warlords organized in the empire’s interstices, and when mobile invaders

(especially Manchus) swept into imperial territory and seized the levers of power. China became the great land of rebellions and civil war, but not of war among multiple states. For that, Europe held the record.

Over the long run, European wars became more lethal and less frequent. Drawing on the pioneer work of Pitirim Sorokin, Jack Levy has compiled a catalog of larger wars involving great powers – European or otherwise – from 1495 through 1975 (see table 3.1). His catalog, which requires at a minimum 1,000 battle deaths per year, is much smaller than Evan Luard’s attempt at a comprehensive listing of all substantial wars over a comparable period, but Levy sets clearer criteria for inclusion and provides more detail on the wars he does include (see Levy 1983, Luard 1987). Over the centuries, the number of great power wars, their average duration, and the proportion of all years in which such wars were in progress all dropped dramatically (Levy 1983: 88–91, 139). William Eckhardt’s list of all wars – great power and other, international and civil, combined – includes 50 for the eighteenth century, 208 for the nineteenth, and 213 for the twentieth through 1987 (Eckhardt 1988: 7; Sivard 1988: 28–31).

Table 3.1 Wars involving great powers

Century	Number of wars	Average duration of wars (years)	Proportion of years war underway (%)
16th	34	1.6	95
17th	29	1.7	94
18th	17	1.0	78
19th	20	0.4	40
20th ^a	15	0.4	53

^a through 1975
Source: Levy 1983, Luard 1987

In addition, the intensity of war altered significantly. Figure 3.1 captures some of the alteration by means of a device borrowed from the analysis of strikes: a solid whose volume represents the total number of battle deaths incurred by great powers per year, and whose three dimensions show the components of total battle deaths. The three components are: number of battle deaths per state participating in great power wars during the average year; number of states participating in those wars during the average year; and average number of wars per state-year of participation. Thus

$$\text{battle deaths per year} = \text{battle deaths per state} \times \text{state-years per war} \times \text{wars per year}$$

which is what the solid shows.

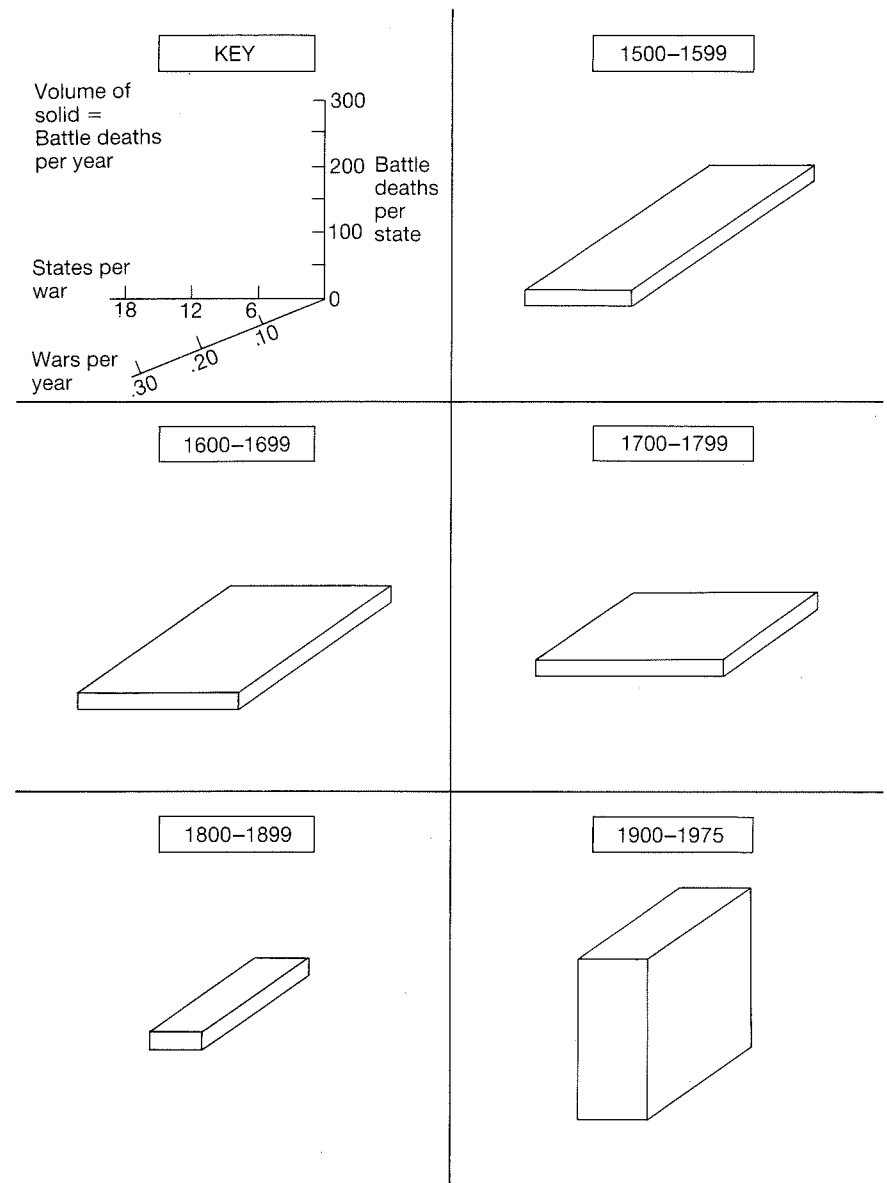

Figure 3.1 Magnitudes of great power war by century, 1500–1975.

Moving from century to century, we see the number of great power battle deaths per state rising from just under 3,000 per year during the sixteenth century to more than 223,000 during the twentieth. The average number of states involved in great power wars rose from 9.4⁶ in the sixteenth century to

17.6 in the eighteenth century, only to fall back to 6.5 in the twentieth. (The rise and fall reveals the development of the general war among most or all of the great powers, counterbalanced in the nineteenth and twentieth centuries by the tendency of Western states to start or intervene in local conflicts outside of the West.) Finally, the number of wars going on in a given year per warmaking state dropped from the sixteenth to eighteenth centuries, then held steady: 0.34, 0.29, 0.17, 0.20, and 0.20. During the sixteenth century, that is, states that ever participated in great power wars were at war during about one year in three (0.34); during the twentieth, one year in five (0.20).

As a result of these changes, the sheer volume of great power deaths per year soared from 9,400 during the sixteenth century to 290,000 during the twentieth. If we could include deaths of civilians and among troops of minor powers, the inflation would surely be even more rapid. With aircraft, tanks, missiles, and nuclear bombs, the death toll of twentieth-century wars far outshadows those of previous centuries.

The numbers are only approximate, but they establish the heavy involvement of European states (which, from the sixteenth to the nineteenth centuries constituted almost all the world's great powers) in warfare, century after century. They also suggest that preparation for war, paying for it, and mending its damage preoccupied rulers throughout the five centuries under scrutiny. In the five centuries before 1500, furthermore, European states concentrated even more exclusively on the making of war. Over the millennium as a whole, war has been the dominant activity of European states.

State budgets, taxes, and debts reflect that reality. Before 1400, in the era of patrimonialism, no state had a national budget in the understood sense of the word. Taxes existed in Europe's more commercialized states, but rulers everywhere acquired most of their revenues from tribute, rents, dues, and fees. Individual sovereigns borrowed money, but usually in their own names and against real collateral. During the sixteenth century, as war multiplied state expenditures through most of the continent, European states began to regularize and expand budgets, taxes, and debts alike. States' future revenues began to serve as security for long-term debt.

France's public debt took on serious proportions when Francis I started borrowing from Parisian businessmen in the 1520s, offering the city's future revenues as security (Hamilton 1950: 246). He spent the money on his great campaigns against Habsburg Emperor Charles V. Although the French national debt fluctuated as a function of war efforts and fiscal policies, in general it galloped upward – to the point at which borrowing for eighteenth-century wars swamped the state, ruined its credit, and led directly to the fateful calling of the Estates General in 1789. Budgets and taxes swelled accordingly: French taxes rose from the equivalent of about 50 hours of an ordinary laborer's wages per capita per year in 1600 to almost 700 hours per capita in 1963 (Tilly 1986: 62).

Great Britain survived without large state debts until the reign of William and Mary. The War of the League of Augsburg (1688–97) elevated the long-term British debt to £22 million. By 1783, after the Seven Years' War and the War of American Independence, it had increased tenfold, to £238 million. In 1939, as Britain rearmed, the public debt reached £8,300 million (Hamilton 1950: 254–7). From the late seventeenth century onward budgets, debts, and taxes arose to the rhythm of war. All of Europe's warmaking states had the same experience.

If war drove states, it did not exhaust their activity. On the contrary: as a by-product of preparations for war, rulers willy-nilly started activities and organizations that eventually took on lives of their own: courts, treasuries, systems of taxation, regional administrations, public assemblies, and much more. Writing of the sixteenth century, J. H. Elliott notes:

If warfare was a dominant theme in the history of Spain under Charles V and Philip II, bureaucratization was another . . . The replacement of the warrior-king Charles V by a sedentary Philip II, who spent his working day at his desk surrounded by piles of documents, fittingly symbolized the transformation of the Spanish Empire as it passed out of the age of the *conquistador* into the age of the Civil Servant.

(Elliott 1963: 160)

The tasks of fitting out armies and navies were not the only ones which resulted in an expanding governmental structure. No monarch could make war without securing the acquiescence of nearly all of his subject population, and the active cooperation of at least a crucial few. Over and over, rulers sent troops to enforce the collection of tribute, taxes, and levies of men or materials. But they also allowed localities to buy off the costly imposition of troops by timely payments of their obligations. In this regard, rulers resembled racketeers: at a price, they offered protection against evils that they themselves would otherwise inflict, or at least allow to be inflicted.

At the level of the state, the organizational division between armed forces oriented to attacks on external enemies (armies) and those oriented to control of the national population (police) developed only slowly, and never became complete. Problems of policing differ systematically between rural areas (where, among other things, large proportions of land tend to be in private space, forbidden to public authorities) and urban areas (where much land is public space, accessible to anyone); a military style of policing on call suits most rural areas, while systematic patrolling and surveillance becomes possible in urban areas (Stinchcombe 1963). As a consequence of these and other differences, cities generally developed distinct police forces well before the countryside, and the separation of police forces from other military organizations occurred earlier in relatively urban states.

Well into the seventeenth century, most large European states, by virtue of their reliance on armed and partly autonomous regional magnates for domestic

rule, faced recurrent threats of civil war as magnates took up arms against rulers. During the critical centuries from 1400 to 1700, rulers spent much of their effort disarming, isolating, or co-opting rival claimants to state power. Although municipalities and rural jurisdictions had created their own small police forces long before, only during the nineteenth century did European states establish uniformed, salaried, bureaucratic police forces specialized in control of the civilian population. They thus freed their armies to concentrate on external conquest and international war.

TRANSITIONS

War wove the European network of national states, and preparation for war created the internal structures of the states within it. The years around 1500 were crucial. Europeans had started using gunpowder seriously in warfare toward the middle of the fourteenth century. Over the following 150 years, the invention and diffusion of firearms had tipped the military advantage toward monarchs who could afford to cast cannon and build the new kinds of fortresses that cannon could not easily shatter. Warfare shifted from battles fought on open plains toward sieges of important cities. Around 1500 costs rose again as mobile siege artillery, and infantry to accompany it, came into widespread use; the development of portable musketry in the early sixteenth century further enhanced the importance of trained, disciplined infantry. At the same time, sailing vessels carrying big guns started to predominate in naval warfare. The larger states north of the Alps, especially France and the Habsburg empire, had the scale to absorb the increased costs, and took advantage of it.

For two more centuries, it is true, some states that concentrated on navies continued to thrive; by some standards the Dutch Republic, with very small land forces, became Europe's leading state during the seventeenth century. Portugal and Venice likewise held their own into the seventeenth century. Insular England prospered as a maritime power before building up its armies during the eighteenth century (Modelski and Thompson 1988: 151–244). Such states drew riches from their colonies, profited from intensive international trade, and took advantage of home bases that seapower could easily defend. Eventually, however, those states that recruited and maintained huge armies from their own national resources – France, Great Britain, and Prussia are the preponderant models – prevailed over all the rest.

On a European scale, then, the late fifteenth century marked an important transition: as the large military states began to feel the stimulus of capitalist expansion, the advantages of the small mercantile states began to disappear. Geopolitics played its part: the end of the Hundred Years' War freed a relatively unified France to look around for spaces to conquer. The multiple states of

Iberia, which were completing the expulsion of Muslim powers from the peninsula, felt the French pressure; in 1463, Louis XI actually annexed the Catalan counties of Roussillon and Cerdagne. The marriage of Ferdinand and Isabella (1474), by joining the crowns of Aragon and Castile, replied to the French threat, and threatened France in its turn. The rivalry of France and Spain then began to reverberate through European politics.

Italy felt the impact of that change first. The papal states, the republics, and the small monarchies of Italy had, of course, long involved themselves in politics outside of the peninsula. Delicately balanced alliances, appeals to outside mediators, and timely marriages played significant parts in their politics. During the eleventh to fourteenth centuries, popes had devoted much of their energy to checking, controlling, or even engineering the elections of German-based Holy Roman emperors. The emperors, in their turn, had typically claimed suzerainty over much of Italy. In short, Italian politics had long connected with politics elsewhere.

Nor were war and international rivalry novelties in the peninsula. During the thirteenth century, Aragon, the Holy Roman Empire, France, and the papacy had all contended for priority in Italy. Many of the century's major battles occurred there. By the 1490s, furthermore, the major powers of Italy – Venice, Milan, Florence, Naples, and the papal states – had been warring with each other intermittently for decades. Their wars, however, had proceeded in a genteel, limited way. Then the usurper-duke Ludovico Sforza of Milan invited Charles VIII of France to press his family's claims to the kingdom of Naples.

With Charles VIII's siege of Naples, not one scourge but two entered Italy. Before 1494, syphilis probably did not exist in Europe; returnees from Columbus's first voyage to America, who had contracted the disease in America, very likely introduced the disease to Spain. Spanish mercenaries at the siege of Naples (1494–5) suffered an epidemic that was almost certainly syphilis, whence it spread throughout the continent. As the plague spread, the French commonly called it "Neapolitan disease," while Neapolitans preferred to call it "the French disease" (Baker and Armelagos 1988). Whatever the precise origin of that first epidemic, Italians soon knew that the French and their mercenaries had returned to the peninsula, with a vengeance. If the French arrived, the Spanish would follow.

The 1490s therefore differed from the past. They differed in bringing not just ambassadors, princes, and imperial forces, but large armies from the waxing national states across the Alps, into city-state Italy. The northerners arrived, furthermore, with mobile siege guns and tactics to accompany them, which multiplied the scale and destructiveness of warfare. The French invasion of 1494 made the peninsula Europe's battleground, ended the round of small-scale wars among autonomous city-states, and shocked Italian thinkers.

Their shock resulted from the fact that barbarian forces had once again overrun the homeland of civilization. As J. R. Hale puts it:

The change that came over the nature of warfare after 1494 was overstressed by Machiavelli in the interest of proving a thesis about the relative merits of militiamen to *condottieri*, as it was by Guicciardini in the interest of turning the knife in the wound to Italy's self-esteem, but a change there certainly was, and it was greeted with widespread horror. This horror, however, was not directed against large-scale war as such, as opposed to earlier small-scale wars, nor even against a long period of such wars; nor was it directed to any important extent against the changed nature of war – more bloody, more total, more expensive. It was caused by the evidence provided by these wars of a failure of morale, a failure of the Italian character to meet their challenge.

(Hale 1983: 360)

A significant portion of Machiavelli's writing about military affairs stemmed from his effort to think through what was happening to the Italian state system, and what to do about it.

What *was* happening to the Italian state system? The national states in formation north of the Alps, by competing for hegemony in Italy, were forcibly integrating it into a larger system spanning much of Europe. Soon after, the Ottoman Empire was expanding deep into European territory, and putting pressure on Italy from the southeast; the reign of Suleyman the Magnificent (1520–66) brought the Turks to the summit of their European power. The Ottoman advance, in its turn, started a four-century struggle with Russia, aligning the strategically-located Crimean Tatars with the Ottomans and against the Russians for the first time.

In Italy, the alteration of warfare had devastating consequences. By the 1520s, Habsburgs and Valois were fighting their dynastic wars on Italian territory. In 1527, the Habsburg emperor's mercenaries sacked Rome. As of 1540, Milan and Lombardy had fallen under Spanish rule, France occupied much of Savoy and Piedmont, Florence had become a Medici-ruled duchy nominally subject to the empire, and Naples was an appanage of the Spanish crown. Of the greater Italian powers, only the most maritime, Venice and Genoa, had maintained their oligarchic institutions. Even they lost their pre-eminence in the Mediterranean.

As the northern states generalized their wars and drew Italy into their struggles, war on land became more important, and the ability to field large armies more critical to a state's success. France had 18,000 troops under arms in 1494, 32,000 in 1525, and 40,000 in 1552. Spain's forces expanded much faster: from 20,000 soldiers in 1492 to 100,000 in 1532. By 1552, Emperor Charles V had some 148,000 men under arms, a total unprecedented since Roman times (Parker 1988: 45). At Spain's peak, around 1630, 300,000 men served under its banners. The ratio of troops to total population rose significantly. The figures in table 3.2 require many qualifications. The dates are approximate, "England and Wales" means England and Wales through 1600, Great Britain in 1700, and the United Kingdom thereafter, the boundaries of all these states changed continually throughout the period, and the frequent

Table 3.2 Men under arms, Europe 1500–1980

Country	Thousands of troops under arms					Troops as percent of national population				
	1500	1600	1700	1850	1980	1500	1600	1700	1850	1980
Spain	20	200	50	154	342	0.3	2.5	0.7	1.0	0.9
France	18	80	400	439	495	0.1	0.4	2.1	1.2	0.9
England/Wales	25	30	292	201	329	1.0	0.7	5.4	1.1	0.6
Netherlands		20	100	30	115		1.3	5.3	1.0	0.8
Sweden		15	100	63	66		1.5	7.1	1.8	0.8
Russia		35	170	850	3663		0.3	1.2	1.5	1.4

Source: Compiled from Ballbé 1983, Brewer 1989, Corvisier 1976, Flora 1983, Jones 1988, Lynn 1989, Mitchell 1975, Parker 1976, Parker 1988, Reinhard, Armengaud and Dupâquier 1968, Sivard 1983, de Vries 1984, Wrigley and Schofield 1981.

employment of foreign mercenaries meant that between 1500 and 1700 the figures shown here were in most cases much higher than the proportion of the national population under arms. Furthermore, the official and real strengths of armies often differed significantly, especially before 1800. Finally, for reasons this chapter explores, numbers of troops fluctuated dramatically from year to year, depending on public finances and the state of war; in France toward 1700, for example, the peacetime army ran to around 140,000 men, but Louis XIV brought it up to 400,000 in the midst of his great campaigns (Lynn 1989). Nevertheless, the figures make their main point eloquently. During the sixteenth and seventeenth centuries, especially, armies expanded. They became big business.

State budgets, taxes, and debt rose accordingly. Castile's tax revenues rose from less than 900,000 *reales* in 1747 to 26 million in 1504 (Elliott 1963: 80). At the same time, Ferdinand and Isabella borrowed to pay for their wars in Granada and Italy. As Spanish control over Italy deepened, Italian taxation became a prime source of crown income; the Netherlands likewise yielded an important share of Castile's revenue. The Cortes of Catalonia, Aragon, and Valencia, in contrast, successfully resisted royal demands to increase their contributions to the state's warring. By the middle of the sixteenth century, Spain's Italian and Dutch provinces ceased to yield substantial increases; Charles V and Philip II turned increasingly to Castile (where their predecessors had more effectively subjugated nobility, clergy, and cities to royal will) and to America for financial aid (Elliott 1963: 192–3). They also borrowed through anticipations of revenue from both Castile and America, with the result that by 1543, 65 percent of the crown's regular revenues went to payment of annuities (Elliott 1963: 198; for more detail, see Fernandez Albaladejo 1989). Unsurprisingly, the crown went bankrupt, repudiating its debts in 1557.

At the same time, the Swiss – still, at that time, a conquering people – developed new, highly-disciplined infantry tactics that rapidly proved their superiority. The Swiss had established their military mettle in defeating

Burgundy's Charles the Bold repeatedly during the 1470s. Soon almost every power needed its own Swiss soldiers, and the Swiss began substituting the training and export of mercenaries for the conduct of their own wars (Fueter 1919: 10). In the process, the Swiss cantons themselves entered the business of supplying soldiers for pay (Corvisier 1976: 147). Like other exporters of mercenaries, Switzerland already had a substantial number of poor, mobile, semi-proletarianized and late-marrying highlanders who became attractive candidates for military service away from home (Braun 1960). Mercenaries, Swiss and otherwise, displaced armies of clients and citizen militias.

On a small scale, mercenaries had played their part in European wars for centuries. From the time of the crusades, freebooting soldiers from north of the Alps had sold their services to princes, actual and aspiring, all through the Mediterranean. When no one employed them, they extorted and pillaged on their own account (Contamine 1984: 158). During the fourteenth century, Italian city-states started employing small bodies of hired troops. As it accelerated its forcible annexation of adjacent territory in the 1320s, for example, Florence began relying regularly on mercenary cavalry. In the 1380s, democratic Florence engaged – or bought off – the great English mercenary Sir John Hawkwood, who had been pillaging Tuscany since the end of a war between Milan and the papacy left his company jobless. Hawkwood had previously served England, Savoy, Milan, Pisa and the papacy. Unfortunately for Florentine democrats, Hawkwood backed the oligarchy in their successful rising of 1382; Hawkwood “was accorded the rare favor of Florentine citizenship together with a pension for life and exemption from taxation; and when he died in 1394 the grateful government not only honored him with a splendid funeral at public expense, but also commemorated his services by having him painted on the wall of the inner façade of the cathedral mounted on horseback in full panoply of war” (Schevill 1963: 337). Today's tourists still see the curiously secular mural.

In Venice, that great maritime power, the resident nobility long provided its own military commanders on sea and land; they recruited their soldiers and sailors, furthermore, largely from the Venetian population. But by the end of the fourteenth century Venice, like its Italian neighbors, was hiring mercenary captains, *condottieri*, who recruited their own troops and fought the city-state's wars for a handsome price. Since a *condotta* was a contract to make war for a particular sovereign, *condottiere* meant, essentially, contractor. The German word *Unternehmer* conveys the same commercial tone. The *condottieri* were the oilmen of their time, shifting allegiances from deal to deal and sometimes accumulating great wealth; when the mercenary entrepreneur Bartolomeo Colleoni died in 1475, his fortune was “comparable to the riches of the leading banker of the age, Cosimo de' Medici” (Lane 1973a: 233). By 1625 Wallenstein, Duke of Friedland, ran his own domain of 2,000 square miles and used it as a supply base for troops he deployed – at a profit – on behalf of the

Holy Roman Emperor. Instead of allowing his troops to loot indiscriminately, he organized a protection racket, forcing occupied cities to pay lest the soldiers be let loose (Maland 1980: 103). Under Wallenstein, war became a well-oiled business.

War did not merely entail recruiting and paying troops. Warmaking states had to supply them as well. During the later seventeenth century, a typical army of 60,000 men, with its 40,000 horses, consumed almost a million pounds of food per day – some carried with the army, some stored in magazines, the great bulk procured wherever the army was located, but all of it requiring massive expenditure and organization (Van Creveld 1977: 24). At the prices and wages of the time, a million pounds of grain cost the equivalent of the daily wages of about 90,000 ordinary laborers (calculated from Fourastié 1966: 423). In addition to food, armies had to acquire weapons, horses, clothing, and shelter; the larger the armies, the less feasible to have each individual supply his own. From Wallenstein to Louvois, the great seventeenth-century organizers of war involved themselves in supply as much as in battle. That made their big business even bigger.

From the fifteenth to seventeenth centuries – the critical period for European state formation – armies deployed through much of Europe consisted largely of mercenaries recruited by great lords and military entrepreneurs. Similarly, national navies (especially the corsairs who preyed on enemy shipping with authorization from a protector state) commonly grouped hired sailors from all over the continent (Fontenay 1988b). True, states varied in how much, and how long, they relied on mercenaries. Rulers of larger, more powerful states strove to limit their dependence: France, Spain, England, Sweden, and the United Provinces kept their own generals in place while hiring regiments and companies, but smaller states commonly rented whole armies from generals on down. The German Habsburgs relied on local levies until the Thirty Years' War, engaged the great but demanding *condottiere* Wallenstein during the war and then moved to create a standing army during the latter half of the seventeenth century.

Since battles pay off on the size of armies relative to each other rather than on the per capita effort behind them, one can see why relatively prosperous smaller states often rented their armies on the international market. Navies, too, mixed private and public forces. “Until the 1660s,” remarks M. S. Anderson,

a considerable proportion of the French galley-fleet was provided by private entrepreneurs (often Knights of Malta) who owned the galleys they commanded and served the king under contract for a fixed period in return for a specified sum. In Spain in 1616, when the navy was at a very low ebb, of the seventeen vessels in the fleet five were privately owned, hired merely for the summer (the campaigning season at sea as on land), while in the following year another six or seven had to be hired to provide an escort to bring the silver flotas from America into port. In England, of the twenty-five ships which had made up Drake's expedition to the West Indies in 1585 only two were

supplied by the queen; and though he sailed as Elizabeth's admiral and had official instructions, only about a third of the cost of fitting out the expedition was met by the government.

(Anderson 1988: 27; see also Fontenay 1988a, 1988b)

Privateers, who thrived in seventeenth-century sea warfare, came by definition from licensed non-governmental forces.

Rented armies and leased navies lived chiefly on payments made or authorized by agents of the crowns they served. Etymologically, after all, "soldier" carries the meaning "he who fights for pay." The *Söldner* and the *Unternehmer* complemented each other. The peculiarity of the system became clear early on, when in 1515 "two Swiss armies, one in the service of the French king and one in the service of an Italian baron, met on opposing sides in a battle at Marignano in northern Italy and almost completely annihilated each other" (Fischer 1985: 186). The event helped persuade the Swiss to avoid wars of their own, but it did not keep them from shipping mercenaries to other people's battles.

For several centuries, European states found the system of hire-purchase through returns from taxation a convenient way to build armed force. The extreme case of state specialization in the production of mercenaries was no doubt Hesse-Cassel, a small eighteenth-century state that maintained a full 7 percent of its entire population under arms – 12,000 in domestic garrisons that participated in the local economy, and another 12,000 in a well-trained army that the Landgrave rented out for profit (Ingrao 1987: 132). When Britain needed extra troops for its war against rebellious Americans, it turned to Hesse. As a result, in American folk history "Hessian" signifies crass and unpatriotic – in short, mercenary. On the basis of military business, Frederick II (1760–85) built an enlightened despotism complete with poor relief and maternity hospital; most of the programs, however, collapsed as the American war ended and as Europe's states turned to recruiting their own national armies (Ingrao 1987: 196–201). The age of mercenaries was then ending.

Europe's larger states had long struggled to contain mercenaries within armies commanded by their own nationals and controlled by their own civilians. With the eighteenth century, furthermore, the costs and political risks of large-scale mercenary forces led those states' rulers to enlist more and more of their own citizens, and to substitute them for foreign mercenaries where possible. In the early stages of military expansion by means of rented armies, rulers found the raising of armies from their own populations costly and politically risky; the danger of domestic resistance and rebellion remained large. The wars of the French Revolution and Empire capped the trend, and ended the dominance of mercenary armies. As Carl von Clausewitz reflected after Napoleon's defeat:

Whilst, according to the usual way of seeing things, all hopes were placed on a very limited military force in 1793, such a force as no one had any conception of made its

appearance. War had again suddenly become an affair of the people, and that of a people numbering thirty millions, every one of whom regarded himself as a citizen of the State . . . By this participation of the people in the War instead of a Cabinet and an Army, a whole Nation with its natural weight came into the scale. Henceforth, the means available – the efforts which might be called forth – had no longer any definite limits; the energy with which the War itself might be conducted had no longer any counterpoise, and consequently the danger for the adversary had risen to the extreme.

(Clausewitz 1968 [1832]: 384–5)

With a nation in arms, a state's extractive power rose enormously, as did the claims of citizens on their state. Although a call to defend the fatherland stimulated extraordinary support for the efforts of war, reliance on mass conscription, confiscatory taxation, and conversion of production to the ends of war made any state vulnerable to popular resistance, and answerable to popular demands, as never before. From that point onward, the character of war changed, and the relationship between warmaking and civilian politics altered fundamentally.

Given the general move toward monetization and commodification, the disappearance of mercenary armed forces comes as a surprise. Why on earth would states stop buying their soldiers and sailors and substitute for them standing armies based on conscription? Several factors converged on that outcome. The creation of immense armed forces whose obligation to the crown was purely contractual raised the dangers of foot-dragging, rebellion, and even rivalry for political power; a state's own citizens, commanded by members of its own ruling classes, often fought better, more reliably, and more cheaply. The power over the domestic population that rulers gained through the construction of mercenary armies and the infrastructure to support them eventually shifted the balance; as mercenaries became expensive and dangerous in their own right, the chances of effective resistance on the part of the national population declined. As wars became more expensive, the sheer cost of warfare on the scale established by their large rivals overwhelmed the financial resources of all but the most commercialized states. During the eighteenth century, the vast expansion of rural industry opened up alternative economic opportunities to the people of major regions, such as highland Switzerland, that had been exporting soldiers and domestic servants to the rest of Europe, and thus squeezed the supply of mercenaries. The French Revolution and Napoleon gave the *coup de grâce* to the mercenary system by raising huge, effective armies chiefly from France's own expanding territory. By that time, however, even domestically recruited standing armies had to be paid and supplied. From the fifteenth century onward, European states moved decisively toward the creation of paid forces supported by loans and taxes.

The mercenary system had, indeed, a great weakness: when pay came too slowly or not at all, mercenaries commonly mutinied, lived off the land, became bandits, or all three at once; local people paid the price (see Gutmann

1980: 31–71). In the wars of the sixteenth and seventeenth centuries, booty supplemented military income, but fell far short of allowing armies to support themselves. With great variability from state to state, the leasing of armed force from more or less independent entrepreneurs peaked in the seventeenth century, and began to recede during the eighteenth. Over three or four centuries, nevertheless, mercenaries set the European standard of military performance. For the most part, entrepreneurs who served armies bought food, arms, uniforms, shelter, and means of transport either directly or through allowances to subordinate officers. For that, they needed money, and plenty of it. In 1502 Robert de Balsac, veteran of the Italian campaigns, concluded a treatise on the art of war with advice to any prince: “most important of all, success in war depends on having enough money to provide whatever the enterprise needs” (Hale 1967: 276).

SEIZING, MAKING, OR BUYING COERCION

By 1502, most European princes already knew de Balsac’s lesson by heart. Roughly speaking, rulers had three main ways of acquiring concentrated means of coercion: they could seize them, make them, or buy them. Before the twentieth century, few European states ever manufactured a major share of their own coercive means; they rarely possessed the necessary capital or expertise. Such expensive and dangerous manufactures as gunpowder and cannon constituted the chief exceptions. Increasingly after AD 990, European states moved away from direct seizure and toward purchase.

Several important changes pushed them in the same direction. First, as war became more complex and capital-intensive, fewer and fewer people in the civilian population had the means of war; every thirteenth-century noble household owned swords, but no twentieth-century household owns an aircraft carrier. Second, rulers deliberately disarmed their civilian populations as they armed their troops, thus sharpening the distinction between those who controlled the means of war and those whom the monarch ordinarily wanted to pay for war. Third, states involved themselves increasingly in producing the means of warfare, which restated the question as a choice between seizing and buying the means of production instead of the products themselves. Fourth, the mass of the subject population resisted direct seizure of men, food, weapons, transport, and other means of war much more vigorously and effectively than they fought against paying for them. Although various forms of conscription have continued to our own time, European states generally moved toward a system of collecting taxes in money, paying for coercive means with the money thus collected, and using some of the coercive means to further the collection of taxes.

Such a system only worked well under two very demanding conditions: a

relatively monetized economy, and the ready availability of credit. In an economy where only a small share of goods and services are bought and sold, a number of conditions prevail: collectors of revenue are unable to observe or evaluate resources with any accuracy, many people have claims on any particular resource, and the loss of that resource is hard for the loser to repair. As a result, any taxation imposed is inefficient, visibly unjust, and quite likely to stir up resistance. When little credit is available, even in a monetized economy, current spending depends on cash on hand, and surges in spending can only occur after careful hoarding. In these circumstances, any ruler who cannot seize the means of war directly from his subject population or acquire it without payment elsewhere is hard pressed to build up his state’s armed force. After 1500, as the means of successful warfare became more and more expensive, the rulers of most European states spent much of their time raising money.

Where did the money come from? In the short run, typically from loans by capitalists and levies on local populations unlucky enough to have troops in their vicinity. In the long run, from one form of taxation or another. Norbert Elias sees an intimate relationship between taxation and military force:

The society of what we call the modern age is characterized, above all in the West, by a certain level of monopolization. Free use of military weapons is denied the individual and reserved to a central authority of whatever kind, and likewise the taxation of the property or income of individuals is concentrated in the hands of a central social authority. The financial means thus flowing into this central authority maintain its monopoly of military force, while this in turn maintains the monopoly of taxation. Neither has in any sense precedence over the other; they are two sides of the same monopoly. If one disappears the other automatically follows, though the monopoly rule may sometimes be shaken more strongly on one side than on the other.

(Elias 1982: II, 104)

Elias’s duo, however, actually forms two voices of a trio. The missing member, credit, links the military monopoly to the monopoly of taxation.

Historically, few large states have ever been able to pay for their military expenditures out of current revenues. Instead, they have coped with the shortfall by one form of borrowing or another: making creditors wait, selling offices, forcing loans from clients, borrowing from bankers who acquired claims on future governmental revenues. If a government and its agents can borrow, they can separate the rhythm of their expenditures from that of their income, and spend ahead of their income. Spending ahead of income makes expensive warmaking easier, since expenditures for men, arms, and other requisites of war usually come in surges, while potential and actual state revenues ordinarily fluctuate much less from one year to the next. A state that borrows quickly, furthermore, can mobilize faster than its enemies, and thus increase its chances of winning a war.

The availability of credit depends on a state’s previous repayment of its debts, to be sure, but it depends even more on the presence of capitalists. Capitalists

serve states, when they are willing to do so, as lenders, as mobilizers of loans, and as managers or even collectors of revenues to repay the loans. European capitalists sometimes combined all these activities in the much-hated figure of the tax farmer, who advanced money to the state in anticipation of taxes he himself collected with the authority and military force of the state, and charged a handsome cut of the taxes as his payment for credit, risk, and effort. But even more often capitalists served as major organizers and holders of public debt. Their activity also promoted monetization of a state's economy; some of the crucial relationships are summarized in figure 3.2. These are not the only relationships affecting the variables in the scheme. A crown's direct access to easily sold resources, for example, made it more attractive to creditors, and occasionally provided an alternative to borrowing. So long as gold and silver flowed in from the Americas, Spanish kings found willing lenders in Augsburg, Antwerp, Amsterdam, and elsewhere. In the age of mass mobilization and huge citizen armies that began with the French Revolution, the sheer size of a state's population began to figure very largely in the ease of warmaking. Even then the relationships among capitalist activity, monetization, available credit, and ease of warmaking made a major difference among the states of Europe; they gave states that had ready access to capitalists signal advantages in moving quickly to a war footing.

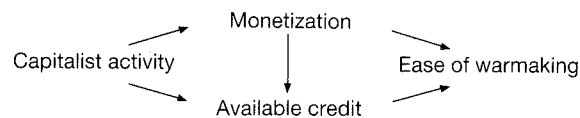

Figure 3.2 How the presence of capital facilitates warmaking.

The relative presence or absence of commercial cities within a state's territories therefore strongly affected the ease of its mobilization for war. Not only did loans and taxes flow more readily into state coffers where cities abounded – given sufficient state attention to the burghers' interests inside and outside the territory – but also urban militias and commercial fleets lent themselves readily to adaptation for defense and military predation. Where cities were weak and rare, rulers either went without large loans or resorted to foreign bankers who exacted high prices for their services, enlisted the cooperation of magnates who controlled armed force and likewise demanded privileges in return, and built up cumbersome fiscal apparatuses in the process of taxing a resistant, penniless population.

During the sixteenth century, as the scale of war expanded and the use of mercenaries generalized, the ability to borrow became more and more crucial to military success. South German merchants such as the Fuggers of Augsburg joined their Italian colleagues in lending to kings; the Fuggers borrowed in

Antwerp, for example, to finance Spanish wars, with future deliveries of American silver as collateral. Long-range borrowing obligated monarchs to foreigners they could not easily control, but allowed them to repudiate their debts with less catastrophic effects on their local economies. Eventually the disadvantages outweighed the advantages, and those monarchs who could move toward domestic borrowing. Those who could borrow at home were, of course, especially those whose states included important zones of capitalist enterprise. Around the time of Henry IV (1598–1610), France moved rapidly from dependency on other centers of capital (notably Lyon, a conduit for Italian capital) to Parisian financial dominance, from foreign to French financiers, and from negotiation to enforced payment of taxes (Cornette 1988: 622–4). Although insolvency threatened the crown repeatedly during the following two centuries, that consolidation of fiscal power gave France an enormous advantage in the wars to come.

PAYING THE DEBTS

Whether they borrowed heavily or not, all rulers faced the problem of paying for their wars without destroying the ability of their sources to pay again in the future. They adopted very different fiscal strategies. Governmental revenues in general (“taxes,” in a loose sense of the word) fall into five broad categories: tributes, rents, payments on flows, payments on stocks, and income taxes. *Tributes* include arbitrary payments levied on individuals, groups, or localities; head taxes which are equal across the population or across its major categories constitute a special kind of tribute. *Rents* consist of direct payments for lands, goods, and services supplied contingently to particular users by the state. (Some states – Russia, Sweden, and the Ottoman Empire, for example – gave a special twist to rents by assigning some military officers and civilian officials the rents from crown lands the officers held so long as they remained in royal service.)

Both rents and tributes can easily be collected in kind. Payments on flows and stocks cannot. *Payments on flows* cover excise, customs, tolls, transaction charges, and other collections on transfers or movements; specialists often call them indirect taxes, because they reflect only quite indirectly the taxpayer's ability to pay. *Payments on stocks* divide chiefly into land and property taxes; specialists often call them direct taxes. *Income taxes* (actually a special case of payments on flows) touch current revenues, especially salaries and other monetary revenues.

The five kinds of taxes form a kind of continuum with respect to their dependence on monetization of the ambient economy. They also differ in terms of the amount of continuous surveillance the collector must apply (see figure 3.3). In general, taxes that require little surveillance rely on open use of force more frequently than those that entail continuous surveillance, and

Dependence on monetization

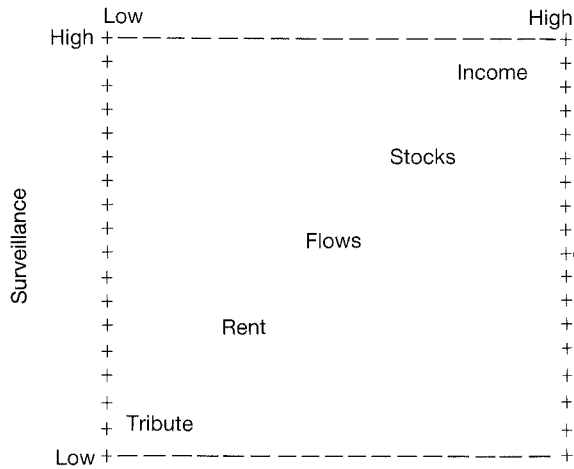

Figure 3.3 Alternative forms of taxation.

therefore promote the development of specialized staffs for evaluation and collection. Governments that have plenty of force at their disposition can collect tributes and rents in relatively unmonetized economies, although even there people's ability to pay cash still depends on their ability to sell goods or services for cash. Even customs revenues depend on the existence of well-defined and well-defended borders; smuggling – the evasion of internal or external customs duties – became a crime precisely to the extent that European states attempted to define and defend their boundaries. In the ages of patrimonialism and brokerage, indeed, states often relied on tolls collected at strategic roads, ports, or waterways instead of customs collected all round a monitored frontier (Maravall 1972: I, 129–33).

Payments on flows depend heavily on monetization, because monetization increases such flows, eases assessors' evaluations of flows, and increases the ability of those who are liable to pay in cash. Payments on stocks, counter-intuitively, also depend heavily on monetization, since in the absence of an active market for the land or property in question assessors lack the means to match tax with value; when the match is poor, the tax is inefficient (see Ardant 1965). Thus monetization strongly affects the effectiveness with which a state can finance its war effort by means of taxation, instead of wresting the means of war directly from its citizenry. The income tax is an extreme case, one that only becomes a durable and effective source of governmental revenue in economies where practically everyone is involved in the money economy and most workers toil for wages.

Highly commercialized states, however, draw some important advantages from

these relationships. Given an appropriate level of monetization, the taxes toward the upper end of the continuum are relatively efficient. They build on the measurement and visibility a commercial economy applies to property, goods, and services. Participants in markets already do a significant share of the requisite surveillance through the recording of prices and transfers. Properly socialized citizens, furthermore, come to attach moral value to the payment of taxes; they monitor themselves and each other, blaming tax evaders as free riders. Taxes on flows, stocks, and especially income therefore yield a high return for a given amount of effort at collection, and adapt more readily than tribute or rents to alterations in state policy. A state attempting to collect exactly the same amount from the same tax in a less commercialized economy faces greater resistance, collects less efficiently, and therefore builds a larger apparatus of control in the process. If two states of similar size but different degrees of commercialization go to war and attempt to extract comparable sums of money from their citizens by means of the same sorts of taxes, the less commercialized state creates a bulkier state structure as it wars and pays for war. The more commercialized state, on the average, makes do with a slimmer administrative organization.

The direct supplying of armies, the imposition of taxes, and the management of royal credit all went more easily in commercialized, capital-rich economies. Wherever they occurred, however, they multiplied the state's civilian servants. A major war effort generally produced a permanent expansion of the state's central apparatus – the number of its full-time personnel, the scope of its institutions, the size of its budget, the extent of its debt. When Holland and Spain reached a truce in their draining war over Dutch claims to independence in 1609, many observers on both sides expected relief from the extraordinary taxation that had beset them during the previous decade. As it turned out, debt service, building of fortifications, and other state activities easily absorbed the revenues freed by military demobilization. Taxes did not decline significantly in either country (Israel 1982: 43–4).

Some historians speak of a "ratchet effect" by which an inflated wartime budget fails to return to its prewar level (Peacock and Wiseman 1961; Rasler and Thompson 1983, 1985a). The ratchet does not occur universally, but it does appear quite often, especially in states that have not suffered great losses in the war at hand. It occurs for three reasons: because the wartime increase in state power gives officials new capacity to extract resources, take on new activities, and defend themselves against cost-cutting; because wars either cause or reveal new problems that call for state attention; and because the wartime accumulation of debt places new burdens on the state.

National debts arose largely from borrowing for and during wars. The ability to borrow for military expenditure strongly affected a state's ability to mount effective military campaigns. The seventeenth-century claims of the Dutch Republic on the financiers of Amsterdam and other major trading cities allowed

ratchet effect of war

a small state to raise enormous sums rapidly for its armies and navies, and to become the dominant European power for a time. The critical innovations had occurred between 1515 and 1565, when the States General of the Habsburg Netherlands (of which the northern provinces, after their rebellion of 1568, would eventually become the Dutch Republic) took steps toward issuing state-backed annuities secured by specific new taxes and bearing attractive interest (Tracy 1985). As a result, "in an emergency, the Dutch Republic could raise a loan of 1 million florins at only 3 percent in two days" (Parker 1976: 212–13). State securities became a favorite investment for Dutch rentiers, whose representatives taxed the entire economy for their benefit. Indeed, the word "capitalist" in its modern use seems to have come from the word for those Dutch citizens who paid the highest per capita tax rate, thereby advertising their wealth and creditworthiness.

Dutch bankers were so affluent, adept, and independent that after 1580, as the war of the northern Netherlands against their former Spanish masters continued, the bankers were able to make money by shipping silver diverted from the Spanish fleet to Antwerp, where it paid for Spanish expenses of the war (Parker 1972: 154–5). When in 1608 Spain proposed to recognize Dutch independence if Holland withdrew from the East and West Indies, Dutch negotiator Oldenbarnevelt "retorted that too many prominent personages in the Republic were involved in the East India Company for it to be disbanded" (Israel 1982: 9). On the whole, however, the merchants' affluence worked to the advantage of their own Dutch state. An intensely commercial economy permitted the seventeenth-century Dutch state to follow a path that the neighboring Prussians found barred and that the English, newly blessed with a Dutch king, borrowed in the 1690s. By adopting Dutch fiscal techniques, the English managed to reduce their previous dependence on Dutch bankers, and eventually to best the Dutch at war.

The seventeenth-century Dutch occupied an extreme position on the axis of commercialization. Other capital-intensive states, such as the Italian commercial powers of Genoa and Venice, adopted similar approaches to the raising of military force through public credit and taxation on flows of goods. In coercion-intensive regions, resources that might be used for war remained embedded in agriculture, and in the hands of magnates who wielded considerable autonomous force; there, the extraction of military resources obviously took very different forms: various combinations of expropriation, co-optation, clientage, conscription, and heavy-handed taxation. In between the two extremes, in areas of capitalized coercion, the more even balance of capital and coercion allowed rulers to play one against the other, using purchased force to check the holders of private armies and national armies to persuade the holders of private capital; in the long run, as the sheer bulk of military requirements rose, the combination gave rulers of capitalized-coercion states the decisive advantage in warfare; as a consequence, their sort of state – the national state –

won out over city-states, empires, urban federations, and other forms of state that had sometimes prospered in Europe.

THE LONG, STRONG ARM OF EMPIRE

By the end of the seventeenth century, a significant part of European war – including war between neighboring Holland and England – was taking place at sea, far from the continent. The struggle for maritime empire complemented European land warfare in shaping distinctive kinds of European states. Before they created national states, Europeans had plenty of experience with empires. Norsemen constructed fleeting empires well before the Millennium. Mongol, Russian, Ottoman, Swedish, Burgundian, and Habsburg empires long dominated significant parts of Europe. Great trading cities such as Genoa and Venice conquered or purchased their own scattered empires. Napoleon built a vast, if short-lived European empire. Ottoman, Austro-Hungarian, Russian, and German empires existed up to World War I. As the centuries rolled on, to be sure, European empires came increasingly to resemble national states. In their heterogeneity and their residues of indirect rule through viceroys or the equivalent, nevertheless, they faced distinctive problems of control over their subject populations.

Beginning in the fifteenth century, European powers moved toward the creation of empires far outside of the continent. Portuguese Christians had eliminated the last Moorish kingdom from their end of the peninsula in 1249. For another century and a half the Portuguese confined their maritime attentions to trade in Europe and Africa, but in 1415 their capture of Ceuta on the Moroccan coast launched an expansion that did not cease for two hundred years. By the time of the death of Prince Henry (the so-called Navigator) in 1460, his forces had extended their control, both political and commercial, well down Africa's western coast as well as seizing Madeira and the Azores in the Atlantic. With the assistance of Genoese *condottieri* and entrepreneurs, they began almost at once to make new colonies commercially viable. Before the century's end Vasco da Gama had sailed around Africa to Calicut, thus extending Portuguese influence into the Indian Ocean and the Pacific.

The Portuguese sought deliberately to break Muslim–Venetian control of European access to Asian spices and luxury goods, and to establish their own hegemony in the sea lanes to Asia. Through great energy, exceptional risk-taking, and supreme ruthlessness, they almost succeeded. During the sixteenth century Portuguese carracks and galleons commanded much of the Indian Ocean, and carried close to half of all spices shipped to Europe and the Ottoman Empire (Boxer 1969: 59). In the course of the same century Portuguese settlers began migrating to Brazil; they started to export sugar produced by the labor of impressed Amerindians and, increasingly, slaves

imported from Angola, Congo, and Senegambia. The Portuguese crown then received a major share of its income from customs duties on goods from its colonies.

Portugal, however, suffered some severe handicaps. Its domestic supply of men, timber, and other resources for imperial adventure remained perilously thin, so much so that sixteenth-century "Portuguese" ships often bore no native Portuguese but their commanders. From 1580 to 1640 Portugal merged with the Spanish crown, and thus inherited Spain's war with the fearsome Dutch. With its rebellion against Spain in 1640, the small kingdom warred against both the Dutch and the Spanish until 1689. Wars with maritime rivals endangered Portuguese merchants on the high seas. That Portugal remained powerful for so long testifies to extraordinary toughness and ingenuity.

As they attached an immense empire to a fragile home base, Portuguese conquerors established characteristic forms of rule overseas, and transformed their own state. Overseas, Portugal made most of its colonies into military outposts, one of whose chief activities was to generate revenues for the crown. Unlike the Dutch, the English, and the Venetians, Portuguese rulers did not license merchants to organize colonial rule. Unlike the Spanish, they did not tolerate the creation of great autonomous domains in their overseas territories. But they could not stop colonial administrators, priests, and soldiers from trading on their own account, or from accepting payoffs for illegal uses of their official powers. Colonial revenues thus made Lisbon and its king relatively independent of powerholders elsewhere in Portugal, but dependent on frequently corrupt officials. Such a monarchy could only prosper when gold and goods flowed freely from the colonies.

As compared to the neighboring Portuguese, Spaniards were latecomers to overseas conquest. In 1492, Granada, last Muslim stronghold on the Iberian peninsula, fell to Castile. By then, the south-driving Spaniards were already beginning settlement of the Canary Islands. The same year, Queen Isabella authorized the Genoese *condottiere* Christopher Columbus to sail west, via the Canaries, in search of India and Cathay. Within fifteen years Spain had functioning colonies in the Caribbean. A century after Granada's fall, Spaniards ruled – however thinly – almost all of Central and South America except Brazil, and had reached out to conquer the Philippines as well.

About that time, Dutch and English seafarers sailed onto the scene. The two nations' civilian-run East and West India companies, not to mention their freebooters, moved aggressively into Portuguese and Spanish waters in the South Atlantic, the Indian Ocean, and the Pacific. During their eighty-year war of independence against Spain, ironically, Dutch merchants made their greatest profits by trading with the enemy; they brought goods from northern Europe to Iberia, and used old commercial ties to penetrate the trading networks of the Spanish and Portuguese empires. That initiated their construction of a world-wide Dutch empire. In the Atlantic, English merchants attached

themselves to Portuguese trade, and became specialists in outwitting royal customs officers. They started as parasites, but soon became the chief organisms in their territories.

Throughout the history of European imperialism, indeed, a new phase usually began with competition between an established dominant in one world region or trade route and a newcomer who attempted either to challenge the hegemon or to outflank him, or both. The early targets of European attack were usually Muslims, but by the fifteenth century Europeans were battling each other for access to the East. Sixteenth-century Portuguese adventurers almost succeeded in reaching around the Venetians who controlled the western end of Europe's land connection with East and South Asia, only to find themselves challenged on the sea by Spain, Holland, and England a century later. The English and Dutch never expelled Portuguese merchants and viceroys from their entire domain, but they ended the supremacy Portugal had enjoyed until 1600. (During the Dutch war of 1647–8, for example, enemy action took 220 vessels from the Portuguese Brazil fleet: Boxer 1969: 221.) The Dutch East India and West India companies governed great empires of their own, gaining the advantage over their competitors "by virtue of their greater control of the market and the internalization of protection costs" (Steensgaard 1974: 11). Over the seventeenth century as a whole, the Dutch became the world's greatest naval and commercial power.

Then the British displaced the Dutch. As Dutch naval strength faltered, British ships came to prevail on most of the world's seas. By the eighteenth century, French corsairs, men-of-war, and merchantmen were likewise venturing to the Americas, Asia, and the Pacific – they made little impact in Africa before the nineteenth century – and further crowding the sea lanes. The eighteenth-century discovery of gold and diamonds in Brazil revived the Portuguese colonial economy, but failed to restore anything like Portugal's sixteenth-century hegemony. France and Britain came late to territorial conquest outside of their own immediate perimeters, but swiftly made up the lag after 1700. By the end of the eighteenth century, Spain, Portugal, the United Provinces, France, and Great Britain all had large overseas empires and world-wide webs of trade; Britain stood above all the rest. Imperial conquest accelerated in the nineteenth century. "Between 1876 and 1915," notes Eric Hobsbawm, "about one-quarter of the globe's land surface was distributed or redistributed as colonies among a half-dozen states" (Hobsbawm 1987: 59). By World War I, Spain, Portugal, and what was then the kingdom of the Netherlands held little more than shreds of their former empires, while the fabric of French and, especially, British dominion stretched across the world.

All these empires combined conquered territories with "factories," recognized trading settlements at the edges of lands governed by indigenous rulers. With exceptions such as Portuguese Macao, no European powers conquered in Japan or China. But the Portuguese, the Spanish, and then the Dutch

maintained commercial enclaves in Japan; during the closed years of the Tokugawa shogunate (1640–1854), the Dutch outpost at Deshima was practically Japan's only point of contact with Europe (Boxer 1965: 237). Over time, however, the European pattern shifted toward conquest and partial settlement. Starting in 1652, for example, even the Dutch – who actually colonized very few of the lands in which they gained commercial hegemony – began to conquer, administer, and settle around the Cape of Good Hope; the word *Afrikaner* began to apply to transplanted Europeans early in the eighteenth century (Boxer 1965: 266). In the nineteenth century especially, European states tried to carve up most of the non-European world into mutually exclusive colonial territories.

Empire overseas did not build up state structure to the same extent as land war at home. Nevertheless, the connection between state and empire ran in both directions: the character of the European state governed the form of its expansion outside of Europe, and the nature of the empire significantly affected the metropole's operation. Capital-intensive states such as Venice and the Dutch Republic reached out chiefly by the ruthless pursuit of trading monopolies, but invested little effort in military conquest and colonization. Coercion-intensive states such as the Norse and the Spanish devoted more of their energy to settlement, enslavement of the indigenous (or imported) labor force, and exaction of tribute. The in-between states, such as Britain and France, entered the imperial game relatively late, and excelled at it by combining the capitalist and coercive strategies.

The capitalist strategy added relatively little bulk to the central state, especially when conducted through essentially private organizations such as the Dutch East India Company. These commercial megaliths, however, became political forces to be contended with in their own right; thus privatization pushed the state toward bargaining with its subject population, or at least with the dominant commercial class. The strategy of conquest and settlement, which inevitably called forth durable armies and navies, added to the central state bureaucracy, not to mention the world-wide web of officialdom it called into being. Where it brought in riches – especially in the form of bullion, as in Spain – conquest created an alternative to domestic taxation, and thereby shielded rulers from some of the bargaining that established citizens' rights and set limits on state prerogatives elsewhere.

On both the domestic and overseas fronts, how much state apparatus emerged from the interaction between the creation of a military machine and the development of markets depended on several factors: the bulk of the machine in relation to the population that supported it, the prior commercialization of the economy, and the extent to which the state relied on the wartime mobilization of powerholders who provided their own military force and retained the ability to return it to peacetime uses at the end of war. We might imagine a continuum from an imperial Russia in which a cumbersome state

apparatus grew up to wrest military men and resources from a huge but uncommercialized economy to a Dutch Republic which relied heavily on navies, ran its military forces on temporary grants from its city-dominated provinces, easily drew taxes from customs and excise, and never created a substantial central bureaucracy. In between we would place cases such as France and Prussia, where kings had access to important regions of agricultural and commercial capitalism, but had to bargain with powerful landlords for support of their military activity. In the long run, military requirements for men, money, and supplies grew so demanding that rulers bargained with the bulk of the population as well. The next chapter focuses on that bargaining and its variations from one sort of state to another.